



### GENERAL DESCRIPTION

The ME15N10 is the N-Channel logic enhancement mode power field effect transistors, using high cell density, DMOS trench technology. This high density process is especially tailored to minimize on state resistance. These devices are particularly suited for low voltage application such as cellular phone, notebook computer power management and other battery powered circuits, and low in-line power loss that are needed in a very small outline surface mount package.

### FEATURES

- $R_{DS(ON)}$  100 m @VGS=10V
- Super high density cell design for extremely low  $R_{DS(ON)}$
- Exceptional on-resistance and maximum DC current capability

### APPLICATIONS

- Power Management in Note book
- DC/DC Converter
- Load Switch
- LCD Display inverter

### PIN CONFIGURATION

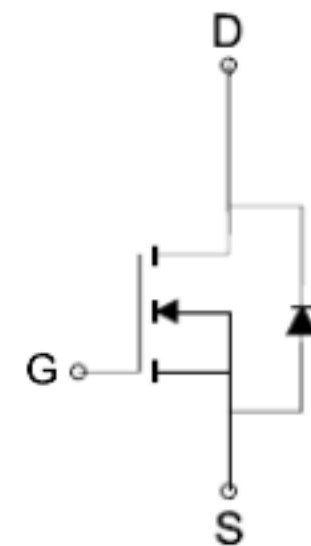
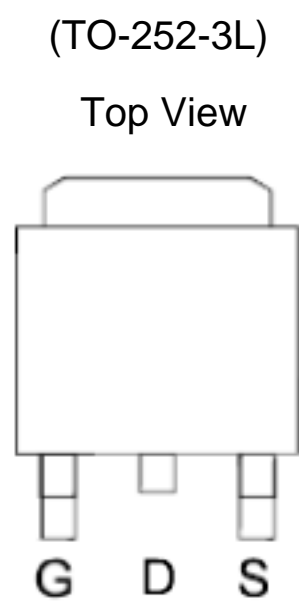

N-Channel MOSFET

- Ordering Information : ME15N10 (Pb-free)  
ME15N10-G (Green product-Halogen free)

### Absolute Maximum Ratings (TA=25 Unless Otherwise Noted)

Parameter Symbol		Rating	Unit
Drain-Source Voltage		$V_{DSS}$ 100	V
Gate-Source Voltage		$V_{GSS}$ ± 20	V
Continuous Drain Current (Tj=150 )	Tc=25	$I_D$	A
	Tc=70		
Pulsed Drain Current		$I_{DM}$ 59	A
Maximum Power Dissipation	Tc=25	$P_D$	W
	Tc=70		
Operating Junction Temperature		TJ	-55 to 150
Thermal Resistance-Junction to Case *		$R_{JC}$ 3.6	/W

\* The device mounted on 1in<sup>2</sup> FR4 board with 2 oz copper

# ME15N10/ME15N10-G

N-Channel 100-V (D-S) MOSFET

Electrical Characteristics (T<sub>A</sub> =25 Unless Otherwise Specified)

Symbol	Parameter	Limit	Min	Typ	Max	Unit
STATIC						
BV <sub>DSS</sub>	Drain-Source Breakdown Voltage	V <sub>GS</sub> =0V, I <sub>D</sub> =250 μA	100			V
V <sub>GS(th)</sub>	Gate Threshold Voltage	V <sub>DS</sub> =V <sub>GS</sub> , I <sub>D</sub> =250 μA	1		3	V
I <sub>GSS</sub>	Gate Leakage Current	V <sub>DS</sub> =0V, V <sub>GS</sub> ± 20V			± 100	nA
I <sub>DSS</sub>	Zero Gate Voltage Drain Current	V <sub>DS</sub> =80V, V <sub>GS</sub> 0V			1	μA
R <sub>DS(ON)</sub>	Drain-Source On-Resistance <sup>a</sup>	V <sub>GS</sub> =10V, I <sub>D</sub> = 8A		80	100	m
V <sub>SD</sub>	Diode Forward Voltage	I <sub>S</sub> =8A, V <sub>GS</sub> =0V		0.9	1.2	V
DYNAMIC						
Q <sub>g</sub>	Total Gate Charge	V <sub>DS</sub> =80V, V <sub>GS</sub> =10V, I <sub>D</sub> =10A		24		nC
Q <sub>g</sub>	Total Gate Charge	V <sub>DS</sub> =80V, V <sub>GS</sub> =4.5V, I <sub>D</sub> =10A		13		
Q <sub>gs</sub>	Gate-Source Charge			4.6		
Q <sub>gd</sub>	Gate-Drain Charge			7.6		
C <sub>iss</sub>	Input Capacitance	V <sub>DS</sub> =15V, V <sub>GS</sub> =0V, f=1MHz		890		pF
C <sub>oss</sub>	Output Capacitance			58		
C <sub>rss</sub>	Reverse Transfer Capacitance			23		
R <sub>g</sub>	Gate-Resistance	V <sub>DS</sub> =0V, V <sub>GS</sub> =0V, f=1MHz		0.9		
t <sub>d(on)</sub>	Turn-On Delay Time	V <sub>DS</sub> =50V, R <sub>L</sub> =5 Ω, V <sub>GEN</sub> =10V, R <sub>G</sub> =1 Ω		14		ns
t <sub>r</sub>	Turn-On Rise Time			33		
t <sub>d(off)</sub>	Turn-Off Delay Time			39		
t <sub>f</sub>	Turn-Off Fall Time			5		

Notes: a. Pulse test: pulse width 300us, duty cycle 2%, Guaranteed by design, not subject to production testing.

b. Matsuki reserves the right to improve product design, functions and reliability without notice.

# ME15N10/ME15N10-G

N-Channel 100-V (D-S) MOSFET

Typical Characteristics (T<sub>J</sub> = 25 °C Noted)

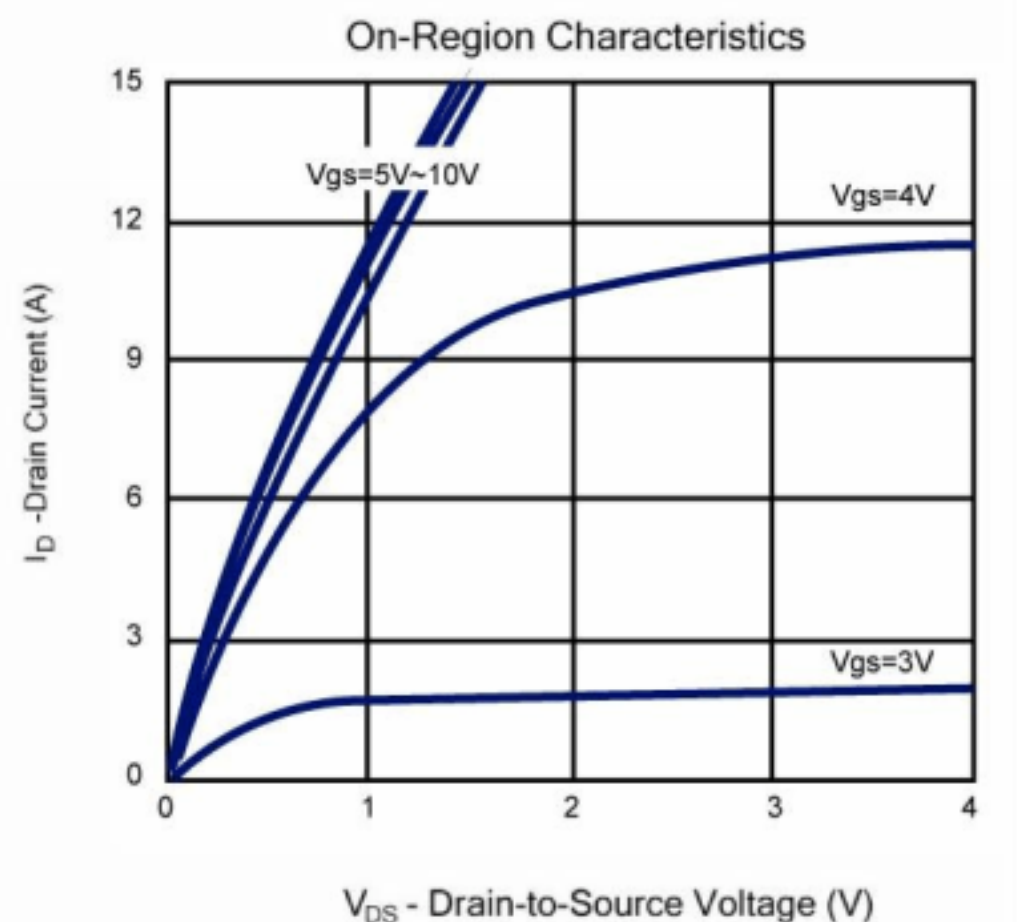
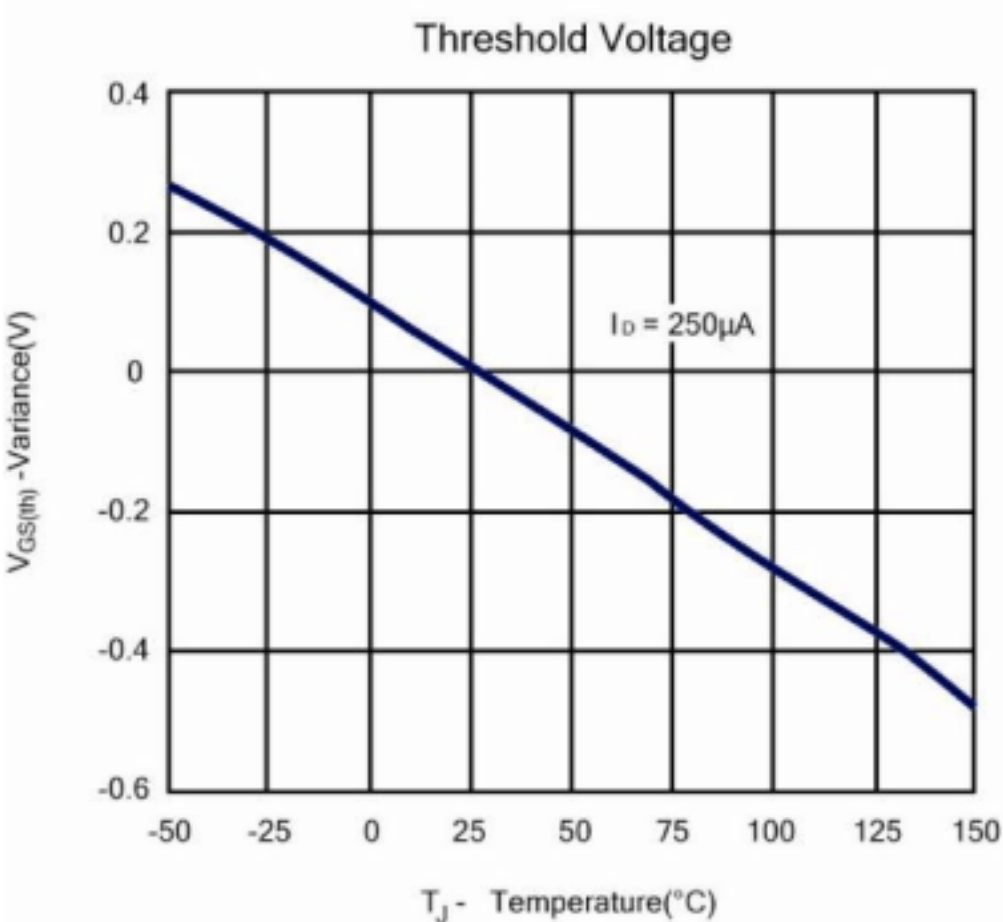
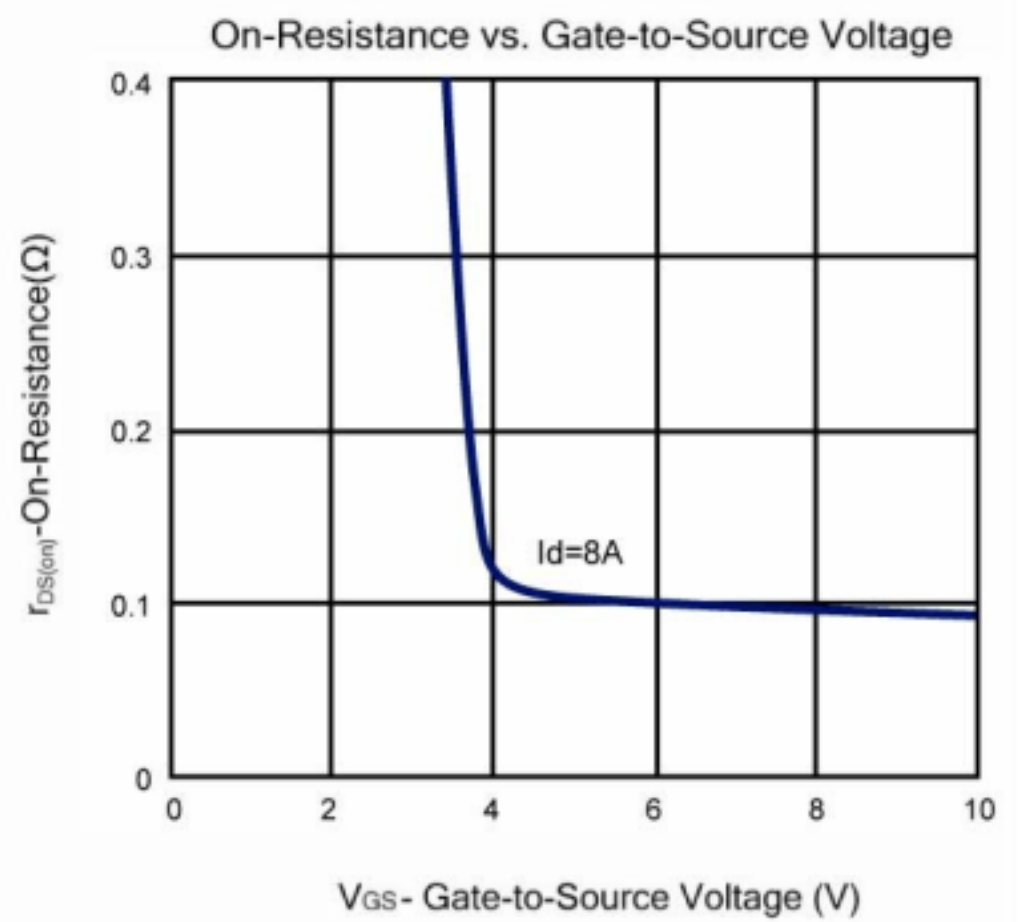
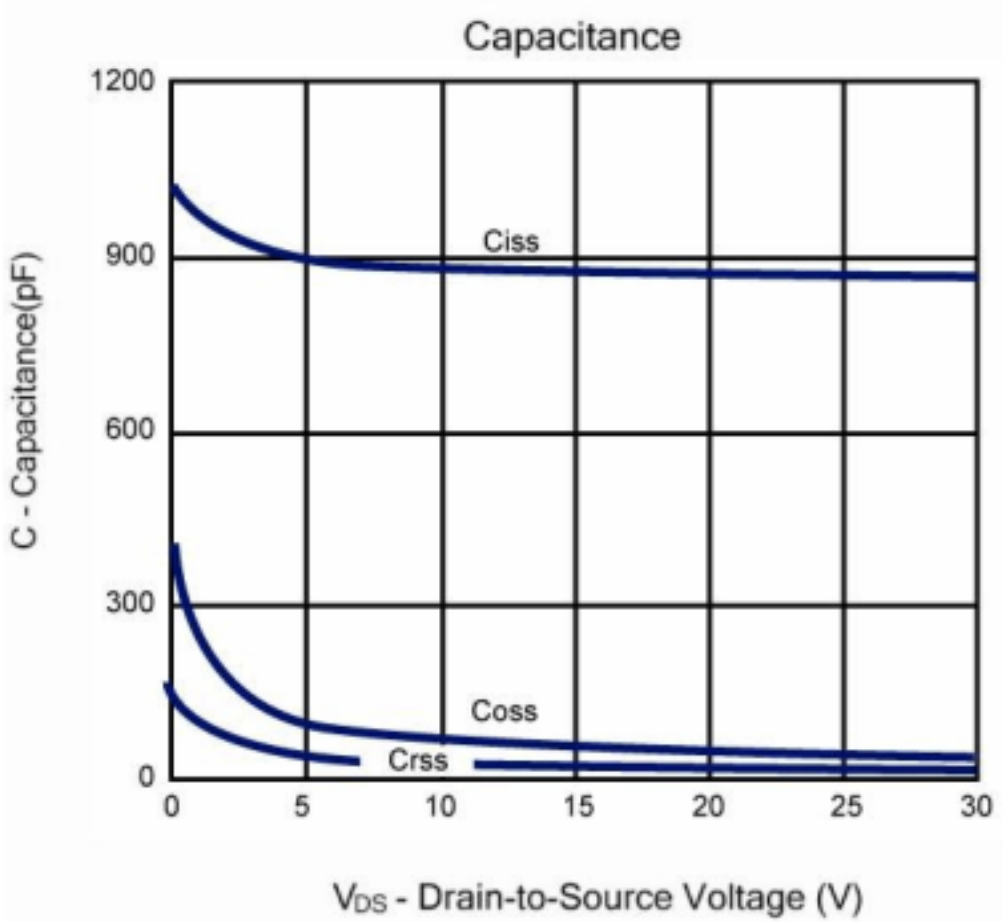
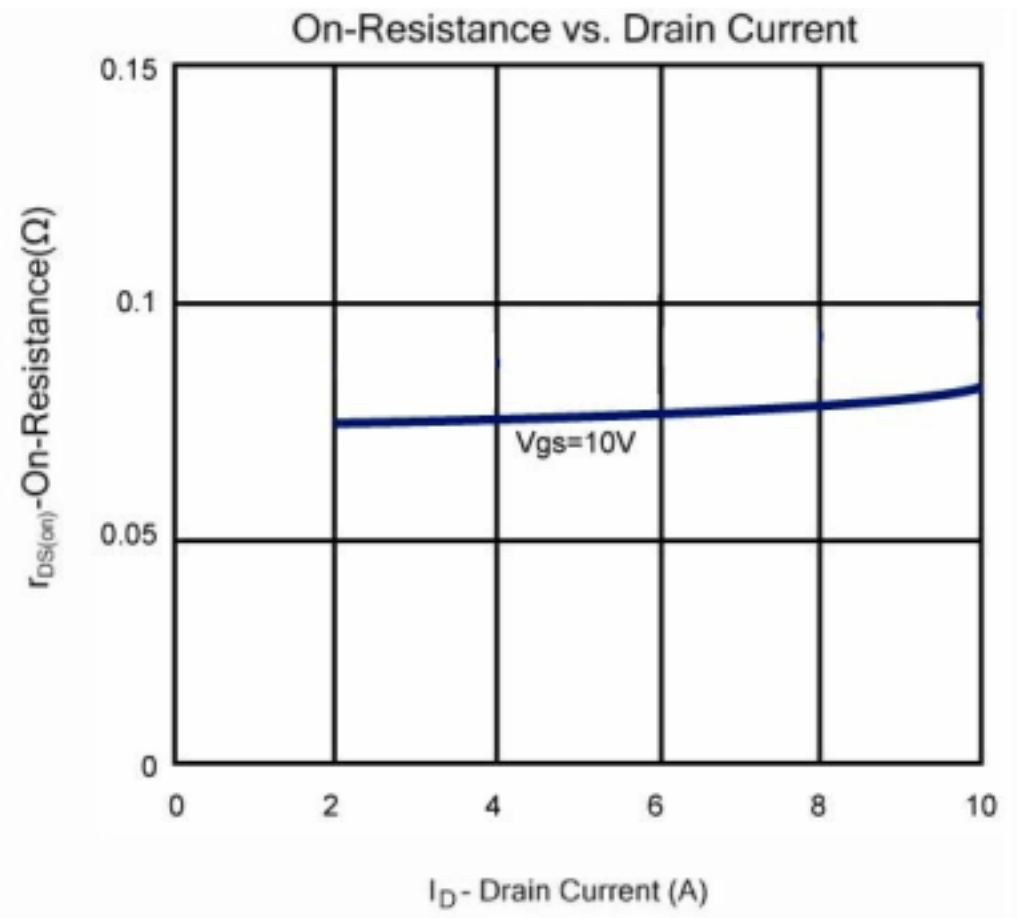
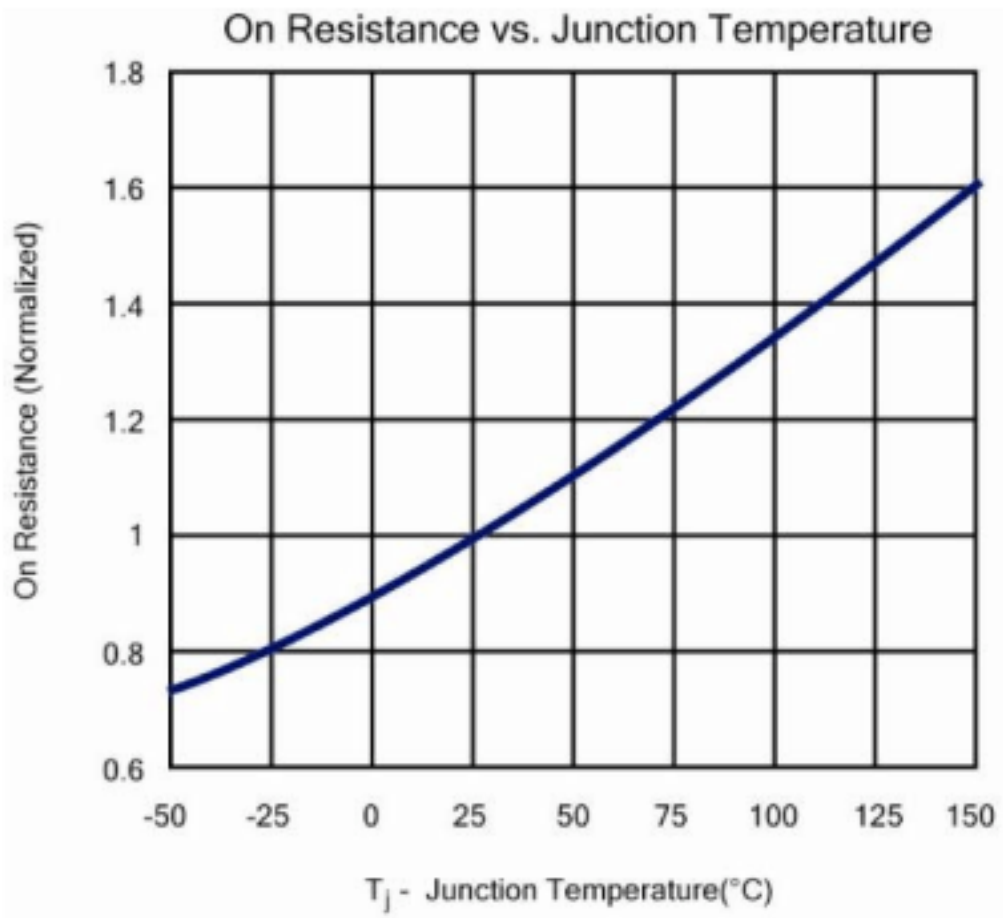



# ME15N10/ME15N10-G

N-Channel 100-V (D-S) MOSFET

Typical Characteristics (T<sub>J</sub> = 25°C Noted)

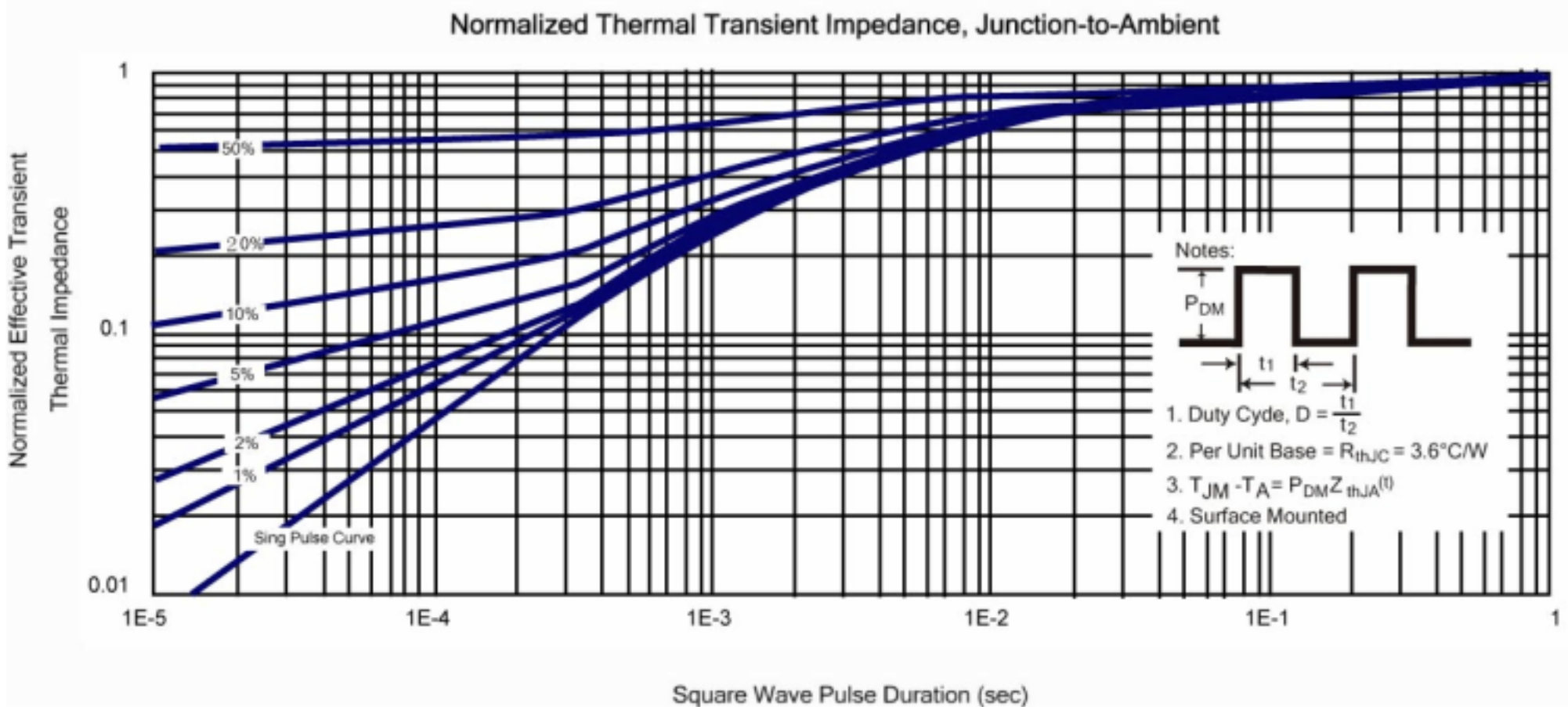
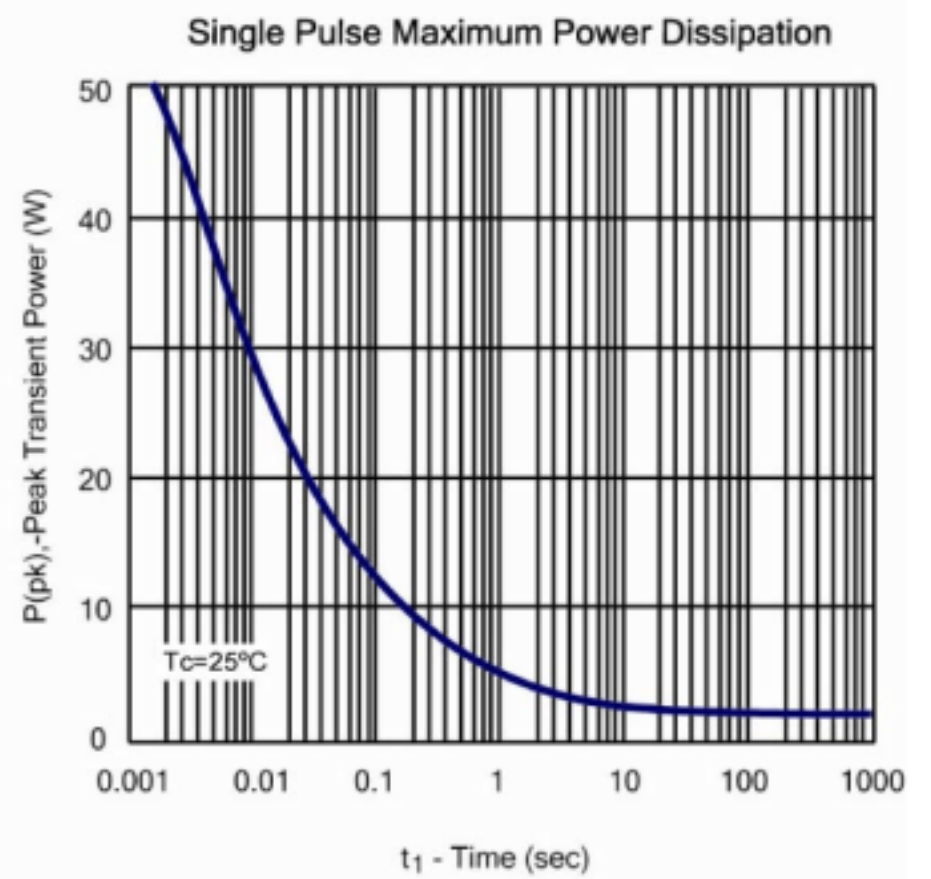
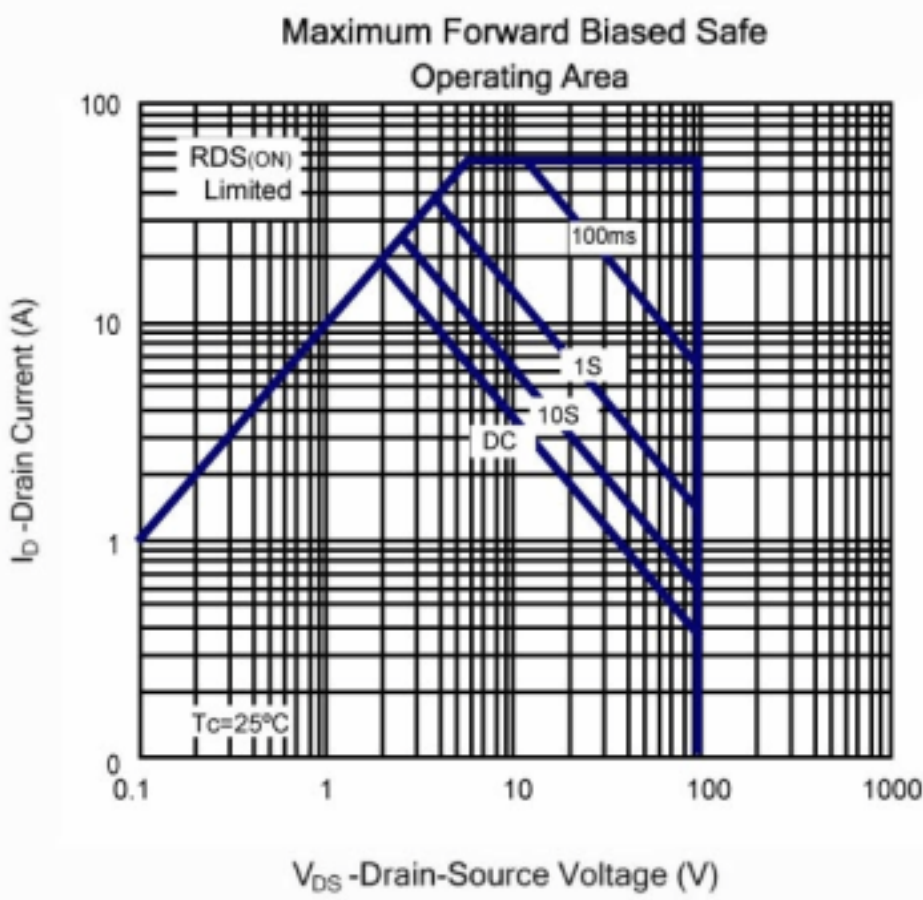
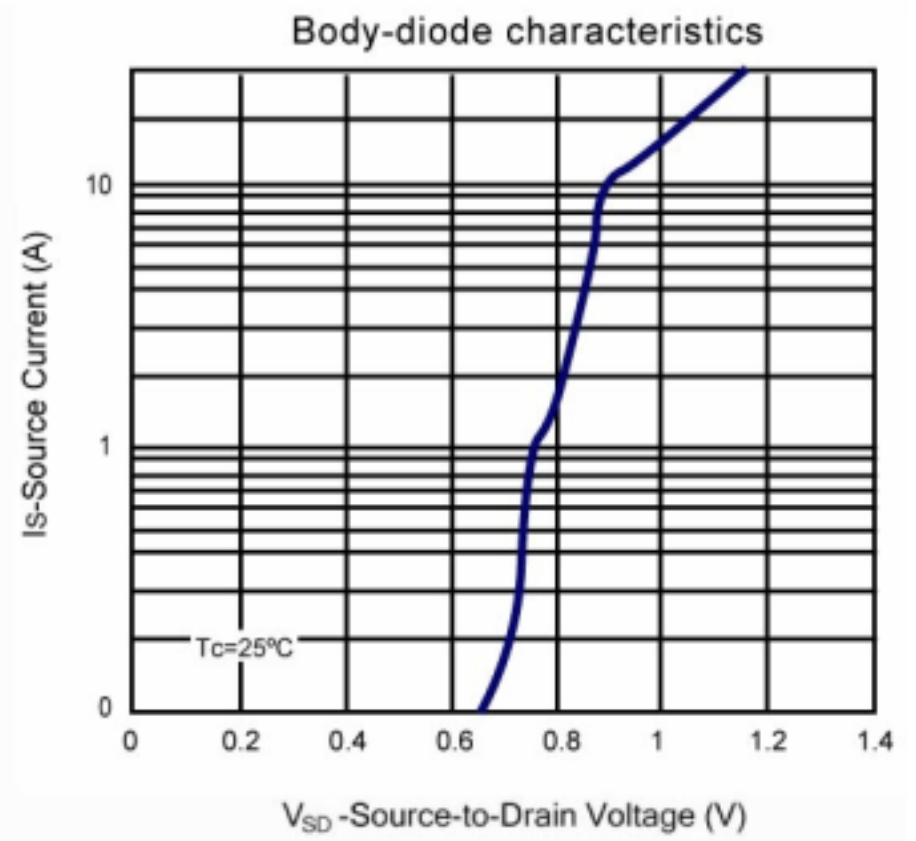
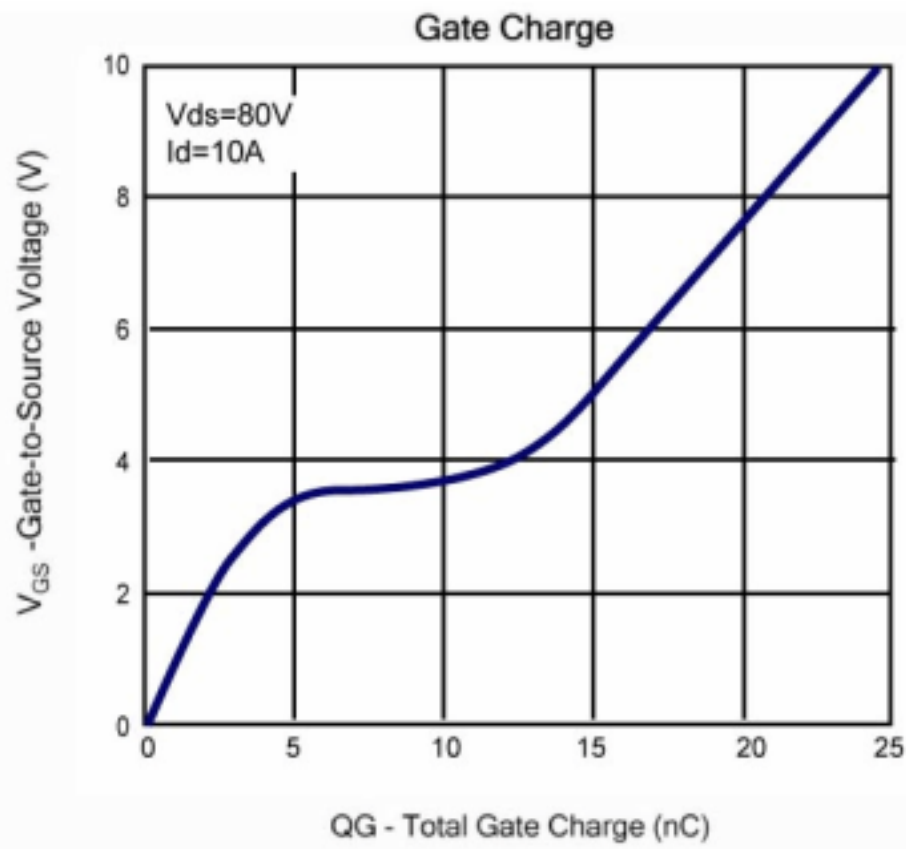

## GENERAL DESCRIPTION

The ME15N10 is the N-Channel logic enhancement mode power field effect transistors, using high cell density, DMOS trench technology. This high density process is especially tailored to minimize on state resistance. These devices are particularly suited for low voltage application such as cellular phone, notebook computer power management and other battery powered circuits, and low in-line power loss that are needed in a very small outline surface mount package.

## FEATURES

$R_{DS(ON)}$  100 m @VGS=10V

Super high density cell design for extremely low R

Exceptional on-resistance and maximum DC current capability

## APPLICATIONS

Power Management in Note book

DC/DC Converter

Load Switch

LCD Display inverter